

# Systems for e-vehicles

## SKAI® 2 IGBT



600V/1200V  
300A

## SKAI® 2 MOSFET Single



200A      100V/150V/200V      400A

## SKAI® 2 MOSFET Dual



150A      100V/150V/200V      400A

$I_D, I_C$  [A]

150

200

300

400

## 3-phase inverter systems up to 250 kVA for electric vehicle applications



### Applications

SEMİKRON's SKAI2 product platform is predestined for use in automotive applications. The systems are designed to operate with battery voltages of 24 - 800 V, output power ratings of 10 - 250 kVA, and are developed in line with the latest automotive and system qualification standards. The standard systems are supplied with low-voltage MOSFETs or high-voltage IGBTs in single or dual configuration.

### Product range

The IGBT-based SKAI2 is available as watercooled 3-phase inverter in voltage classes 600 V or 1200 V, with or without DSP, with an output power of up to 250 kVA. The MOSFET-based SKAI2 is available as forced-air cooled, water-cooled or baseplate type, in voltage classes 100 V, 150 V or 200 V, in single or dual 3-phase inverter topology with an output power of up to 55 kVA.

### Benefits

The high-voltage SKAI2 is available as a water-cooled 600 V or 1200 V IGBT-based 3-phase inverter system. It has been optimized for electrification of commercial vehicle drive trains. This system is based on the established, sintered, and 100 % solder-free power

semiconductor technology for an output power of up to 250 kVA. It features a polypropylene film DC-link capacitor, driver electronics, a state of the art DSP controller, EMC filters, and sensors for current, voltage and temperature monitoring. All system components will be protected by a waterproof IP67 metal case against environmental impacts. The system can communicate with the vehicle master controller via CANbus.

The low-voltage SKAI2 MOSFET 3-phase inverter systems are available in different configurations regarding cooling, battery voltage and topology. It is mainly used in medium power electric vehicle applications with motor power of up to 55 kVA. They have extremely short bus-bar connections between the MOSFET dice and multicell DC bus capacitor, leading to low inductance in the commutation circuit. This results in a switching behavior with very low voltage overshoot. The utilization of maximum MOSFET drain-source voltage as well as power density is high. The inverter is integrated in a waterproof IP67 enclosure but with the cost-effective solution of leaving the power terminals open. Thermal and electrical contact of SKAI2 systems are based on SKiiP pressure-contact technology. This results in extended service life and high load cycling capability.

# Systems - SKAI2

Type	V <sub>battery (max)</sub> V	I <sub>Cnom</sub> A	Topology	Cooling	DSP	Case	Circuit
<b>MOSFET - Three-phase inverter</b>							
SKAI 60 A2 MD10-L <sup>1)</sup>	72	400	3-Phase	Forced Air	Yes	1	
SKAI 60 A2 MD10-P <sup>1)</sup>	72	400	3-Phase	Baseplate	Yes	3	
SKAI 70 A2 MD15-L <sup>1)</sup>	115	350	3-Phase	Forced Air	Yes	1	
SKAI 70 A2 MD15-W <sup>1)</sup>	115	400	3-Phase	Liquid	Yes	2	
SKAI 50 A2 MD20-L <sup>1)</sup>	160	300	3-Phase	Forced Air	Yes	1	
SKAI 50 A2 MD20-W <sup>1)</sup>	160	350	3-Phase	Liquid	Yes	2	
SKAI 60 A2 MM10-L <sup>1)</sup>	72	250	Dual 3-Phase	Forced Air	Yes	4	
SKAI 70 A2 MM15-L <sup>1)</sup>	115	200	Dual 3-Phase	Forced Air	Yes	4	
SKAI 70 A2 MM15-P <sup>1)</sup>	115	200	Dual 3-Phase	Baseplate	Yes	6	
SKAI 70 A2 MM15-W <sup>1)</sup>	115	300	Dual 3-Phase	Liquid	Yes	5	
SKAI 50 A2 MM20-L <sup>1)</sup>	160	150	Dual 3-Phase	Forced Air	Yes	4	
SKAI 50 A2 MM20-W <sup>1)</sup>	160	250	Dual 3-Phase	Liquid	Yes	5	
<b>IGBT - Three-phase inverter</b>							
SKAI 90 A2 GD06-WCI <sup>1)</sup>	450	300	3-Phase	Liquid	Yes	7	
SKAI 45 A2 GD12-WCI <sup>1)</sup>	800	300	3-Phase	Liquid	Yes	7	
SKAI 90 A2 GD06-WDI <sup>1)</sup>	450	300	3-Phase	Liquid	No	7	
SKAI 45 A2 GD12-WDI <sup>1)</sup>	800	300	3-Phase	Liquid	No	7	

## footnotes

<sup>1)</sup> New

## Cases

### Case 1

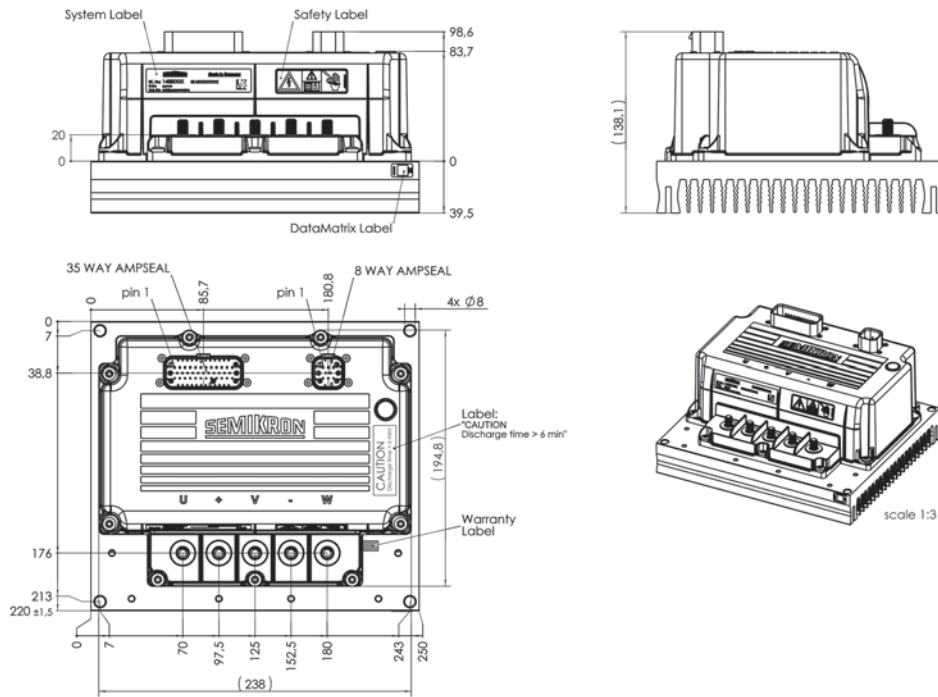

### Case 2

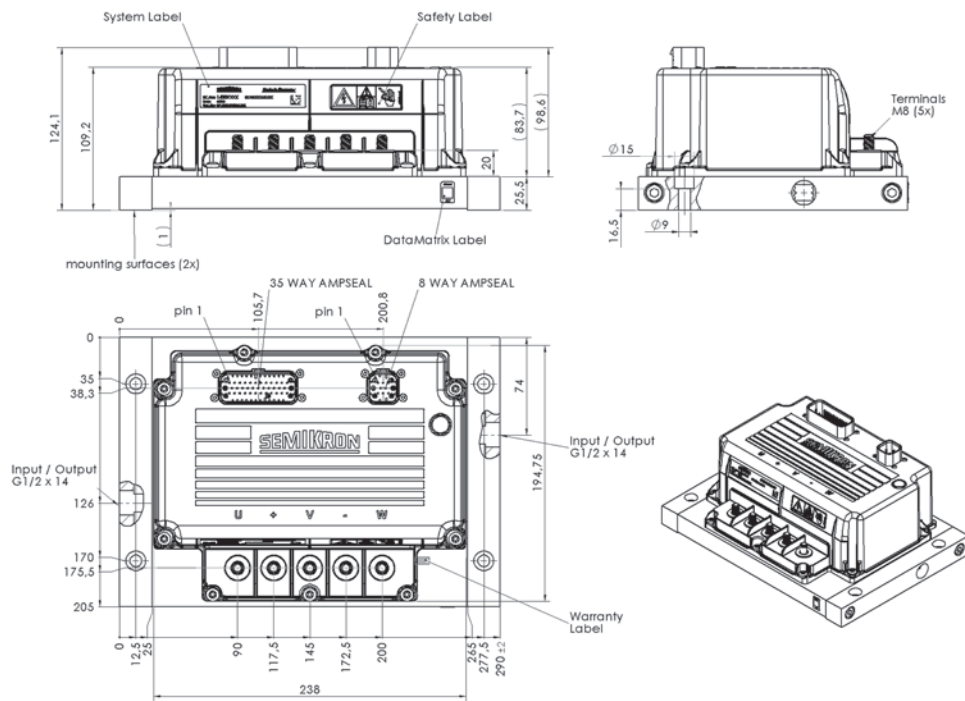

Dimensions in mm

## Cases

### Case 3

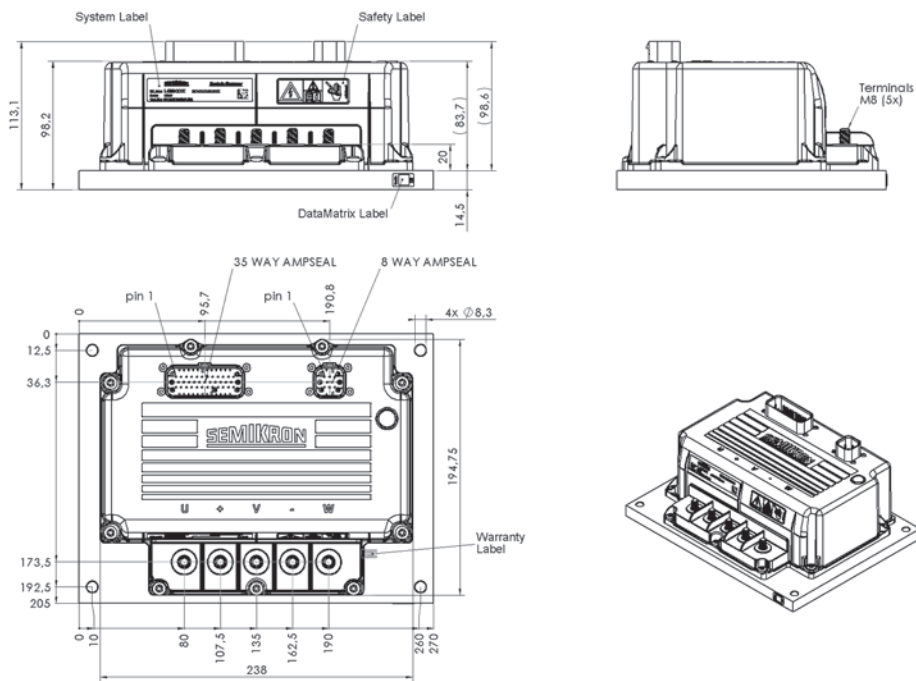

### Case 4

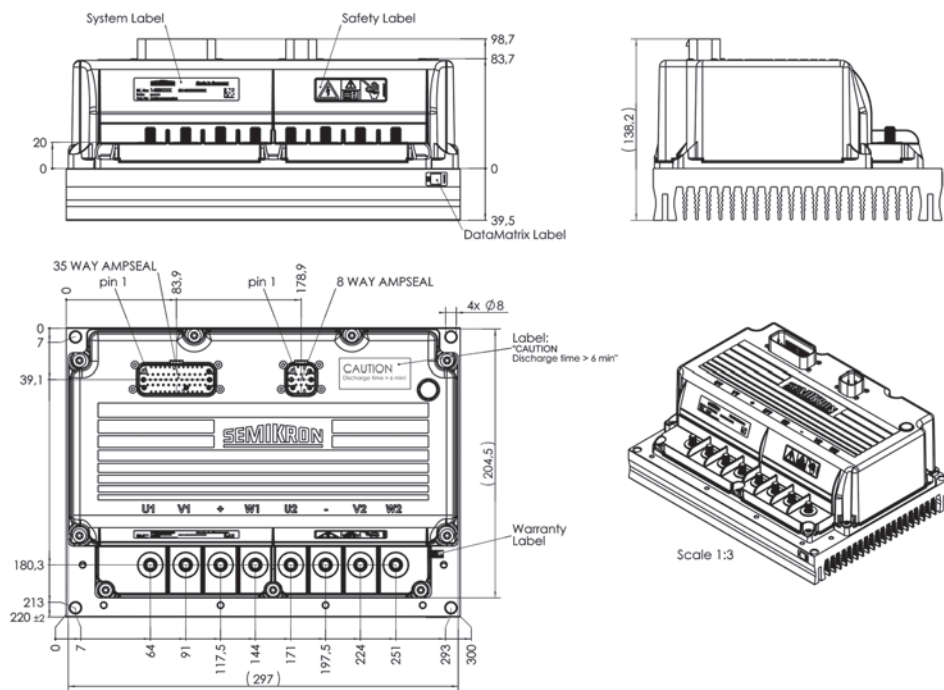

Dimensions in mm

## Cases

### Case 5

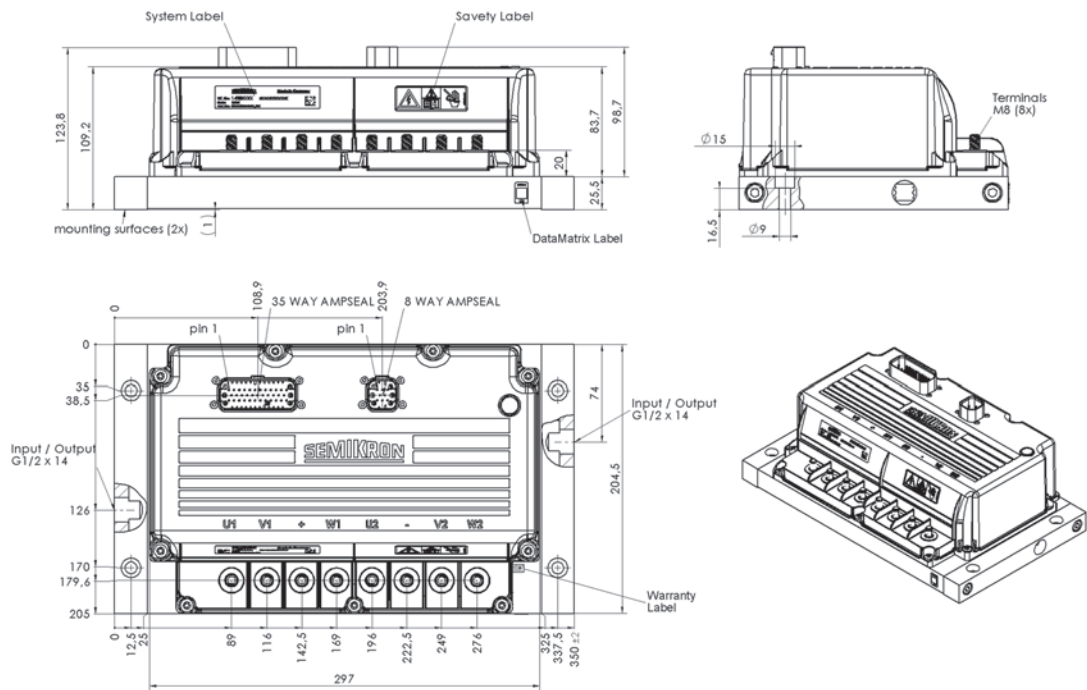

### Case 6

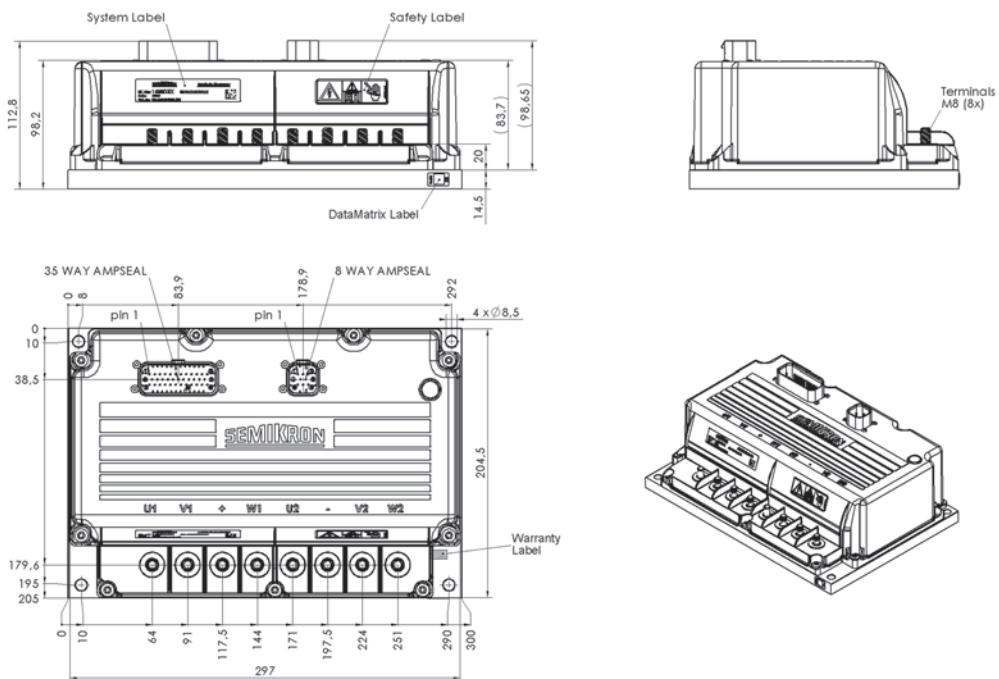

Dimensions in mm

## Cases

### Case 7

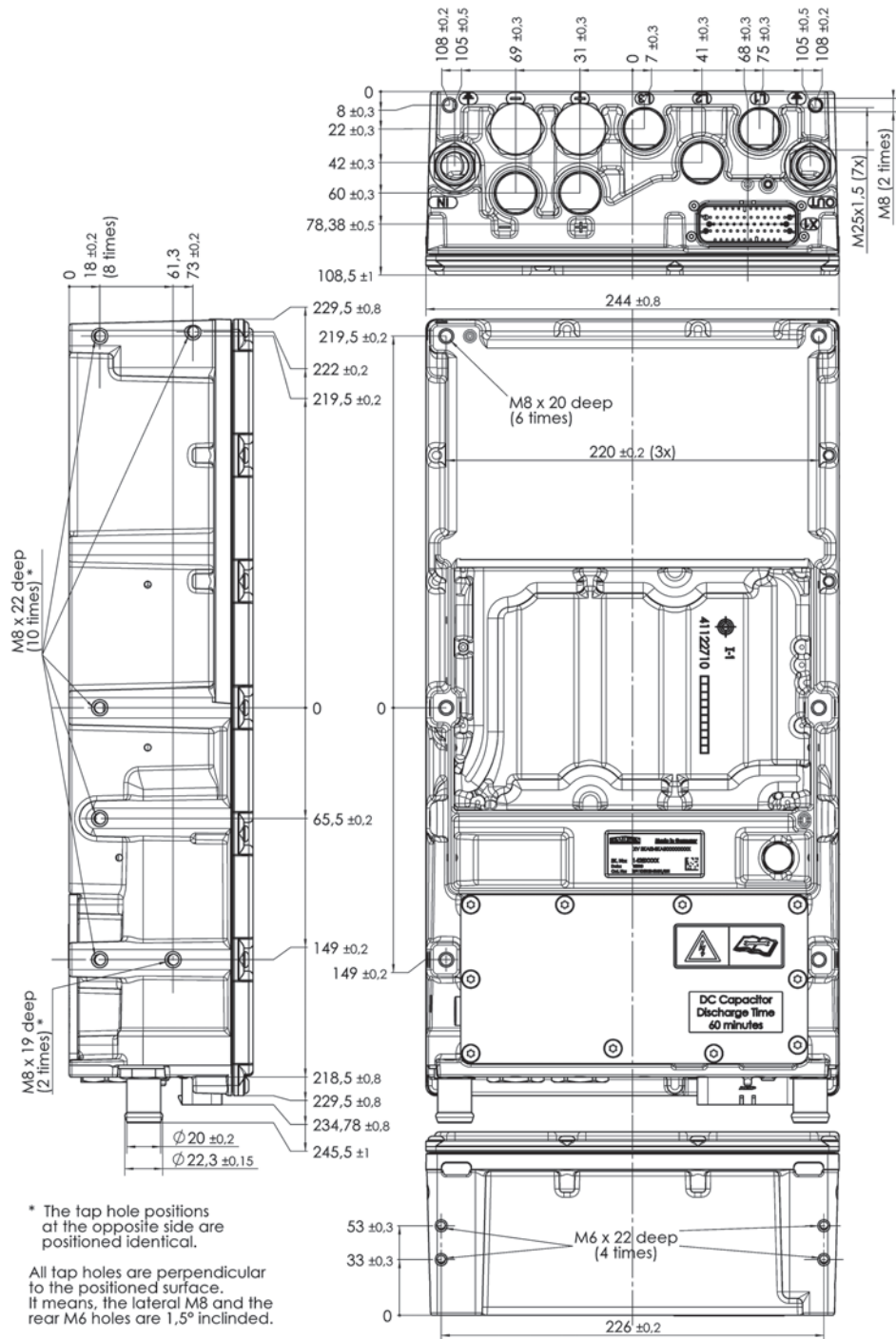

Dimensions in mm



## SindoPower – the eCommerce company of the global SEMIKRON Group

**Buy your power electronics components online!**

Address your requests to us!

### SindoPower Europe & Int.

- English, French, German, Italian, Spanish
- Shipping Europe and worldwide
- Payment in EUR to European bank

+49/911/309196663  
[www.sindopower.com](http://www.sindopower.com)  
[sdp-info@sindopower.com](mailto:sdp-info@sindopower.com)

### SindoPower USA

- English, Spanish
- Shipping USA DDP
- Payment in US-\$ to US bank

+1/603/6854110  
[www.sindopower.com](http://www.sindopower.com)  
[sdp-info@sindopower.com](mailto:sdp-info@sindopower.com)

### SindoPower China

- Chinese, English
- Shipping China Mainland DDP
- Payment in RMB to Chinese bank

+86/756/3396622  
[www.sindopower.cn](http://www.sindopower.cn)  
[sdpcn-info@sindopower.com](mailto:sdpcn-info@sindopower.com)

### SindoPower Brazil

- Portuguese, Spanish, English
- Shipping Brazil DDP
- Payment in R\$ to Brazilian bank

+55/1141/869938  
[www.sindopower.com.br](http://www.sindopower.com.br)  
[sdpbr-info@sindopower.com](mailto:sdpbr-info@sindopower.com)